

## COMMONWEALTH DC BRUSHLESS FAN

# FP-108/DC

120x120x38mm

### DESIGN FEATURES

- \*BEARING SYSTEM: SLEEVE BEARING & BALL BEARING
- \*IMPELLER: PLASTIC WITH FIBER GLASS FILLED UL 94V-0
- \*HOUSING: DIE CAST ALUMINUM PAINTED BLACK OR NATURAL COLOR  
PLASTIC WITH FIBER GLASS FILLED UL 94V-0
- \*MOTOR: BRUSHLESS DC
- \*CONNECTING: WIRE LEADS
- \*SPEED: S-1 HIGH SPEED TYPE  
S-2 MEDIUM SPEED TYPE  
S-3 LOW SPEED TYPE
- \*OTHER VOLTAGE: 36, 48V ARE AVAILABLE
- \*AVAILABLE FG TYPE FOR SPEED SENSOR SIGNAL
- \*AVAILABLE RD TYPE FOR ROTOR LOCKED ALARM SIGNAL



### DIMENSIONS:MM

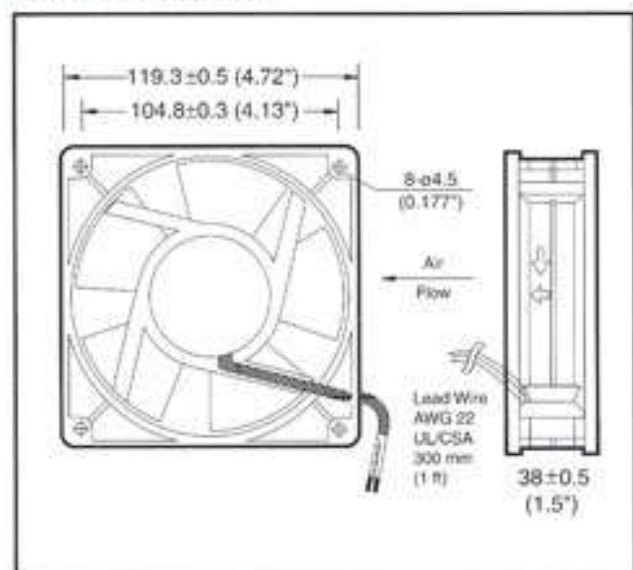

### PERFORMANCE

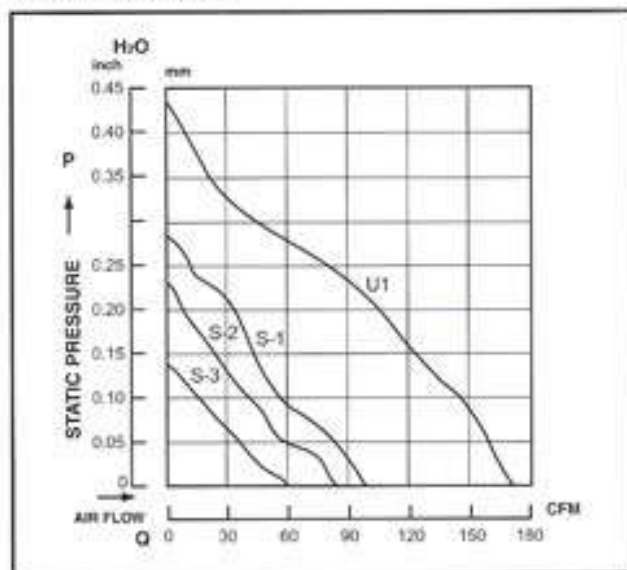

### SPECIFICATIONS

Specifications are subject to change without notice

MODEL NO.	VOLTAGE (VDC)	AIR (CFM)	VOLUME (M <sup>3</sup> /MIN)	CURRENT (A)	POWER (W)	SPEED (RPM)	STATIC PRESSURE (INCH-H <sub>2</sub> O)	NOISE (dBA)
FP-108/DC (U1)	12	168	4.76	1.80	21.60	3400	0.43	50
FP-108/DC (S-1)	12	105	3.00	0.60	7.00	3000	0.28	45
	24	105	3.00	0.36	8.60	3000	0.28	45
	48	105	3.00	0.28	13.44	3000	0.28	45
FP-108/DC (S-2)	12	80	2.42	0.45	5.40	2500	0.23	33
	24	80	2.42	0.28	6.72	2500	0.23	33
	48	80	2.42	0.20	9.60	2500	0.23	33
FP-108/DC (S-3)	12	60	1.70	0.28	3.36	1900	0.14	26
	24	60	1.70	0.14	3.36	1900	0.14	26
	48	60	1.70	0.13	6.24	1900	0.14	26